

**VERTICAL SECTION DOOR DESIGNS**

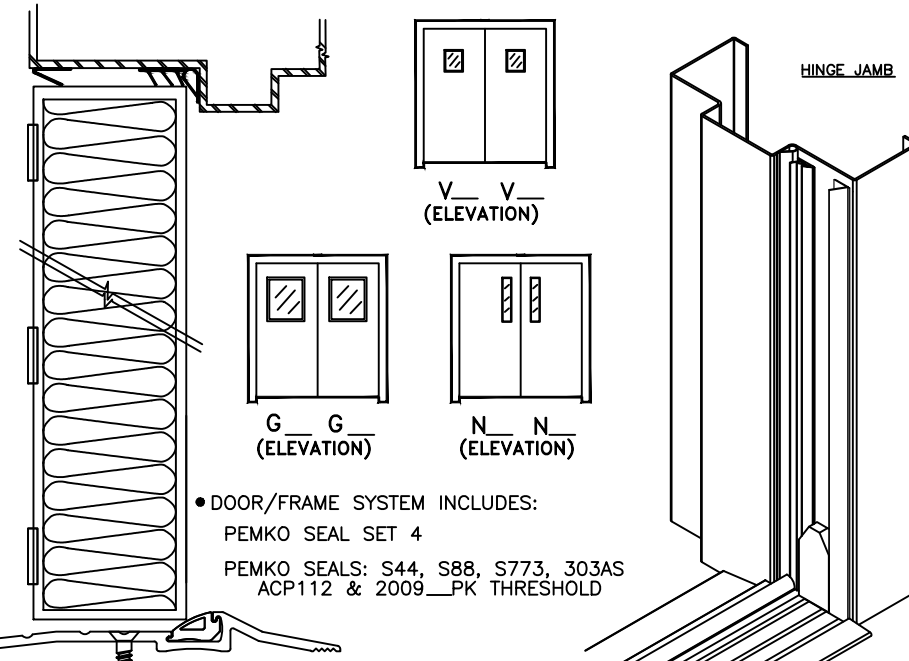

• DOOR/FRAME SYSTEM INCLUDES:  
PEMCO SEAL SET 4  
PEMCO SEALS: S44, S88, S773, 303AS  
ACP112 & 2009 PK THRESHOLD

**STC RATING DOUBLE DOORS**

32	33	34	35	36	37	38	39	40	41	42	43	44
----	----	----	----	----	----	----	----	----	----	----	----	----

NOTES: MUTES ARE NOT ALLOWED. THE ONLY PREPS ALLOWED IN THE HEADER ARE SURFACE CLOSER REINFORCEMENTS. FRAME MUST BE GROUT FILLED STC 40 & ABOVE. STC LABEL WILL BE APPLIED TO THE DOORS ONLY.

- INDUSTRY STANDARD CONSTRUCTION TOLERANCES FOR SQUARENESS OF FRAME INSTALLATION, PLUMBNESS OF WALLS, FLATNESS OF FLOORS, FLANKING, ETC. MAY RESULT IN A DIFFERENCE OF 3dB - 5dB SOUND LOSS IN A FIELD TEST VERSUS LAB TEST.

STC 32 THRU 44 OPTIONAL FIRE RATING:  
TESTS: UL10B, UL10C, NFPA252 & UL1784  
UL LLC & WARNOCK LABEL 20 MIN. THRU 3 HOURS

100" MAX. OF GLASS UP TO (3) HOUR FIRE RATING  
288" MAX. OF GLASS UP TO (1-1/2) HOUR FIRE RATING  
720" MAX. OF GLASS UP TO (1-1/2) HOUR FIRE RATING

GLASS IS FACTORY INSTALLED.

**STC 32-44, 1 3/4" Sound-Tech Xpress, Acoustical Door System**



**ASSA ABLOY** (Conversion: 1" = 25.4 mm, e.g., 1-3/4" = 44.45 mm)

DRAWN BY _____	DATE _____			
CHK'D BY _____	DATE _____			
SHT _____	CONTRACT NO. _____	ISSUE DATE _____	REVISIONS _____	BY _____

**FOR HAND & SWING**  
SEE DOOR SCHEDULE

**FOR ANCHORAGE**  
SEE DOOR SCHEDULE & ANCHOR SHEET

**STRIKE: ANSI 4-7/8" INACTIVE LOCK EDGE**  
**CLOSERS: SURFACE MOUNTED**

NOTE: FOR DESIGN, OR HDWE. REQUIRED, SEE DOOR AND HDWE. SCHEDULE.

FINISH: STANDARD PRIMER PAINT; TESTED IN CONFORMANCE WITH ANSI A250.10

ACOUSTICAL PERFORMANCE: DOOR SYSTEM TESTED IN CONFORMANCE WITH ASTM E2235, ASTM E1332, ASTM E90 & E413, FULLY OPERABLE, STC AS NOTED ABOVE. DOOR SYSTEMS ARE IN COMPLIANCE WITH HMMA 865 & SDI-128 SPECIFICATIONS.

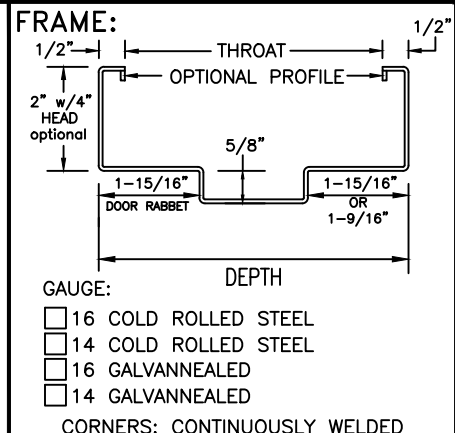

**DOOR:**

**GAUGE:**

- 18 COLD ROLLED STEEL
- 16 COLD ROLLED STEEL
- 18 GALVANNEALED
- 16 GALVANNEALED

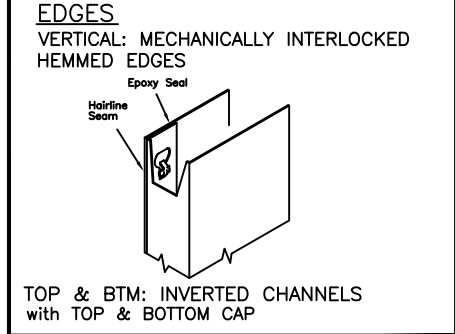

**HDWE PREPS:**

**HINGES:**  
4.5" x .134, 4.5" x .180,  
5" x .146 or 5" x .190, FULL MORTISE, ANSI A156.7

**LOCK:**

- UP TO STC 44 CYLINDRICAL LOCK with 100" of GLASS
- UP TO STC 43 MORTISE LOCK with 100" of GLASS
- UP TO STC 42 MORTISE PANIC with 100" of GLASS
- UP TO STC 41 CYLINDRICAL LOCK with 288" of GLASS
- UP TO STC 40 MORTISE LOCK with 288" of GLASS
- UP TO STC 39 MORTISE PANIC with 288" of GLASS
- UP TO STC 37 CYLINDRICAL LOCK with 720" of GLASS
- UP TO STC 36 MORTISE LOCK with 720" of GLASS
- UP TO STC 35 MORTISE PANIC with 720" of GLASS